

Type I Rough Opening Requirements

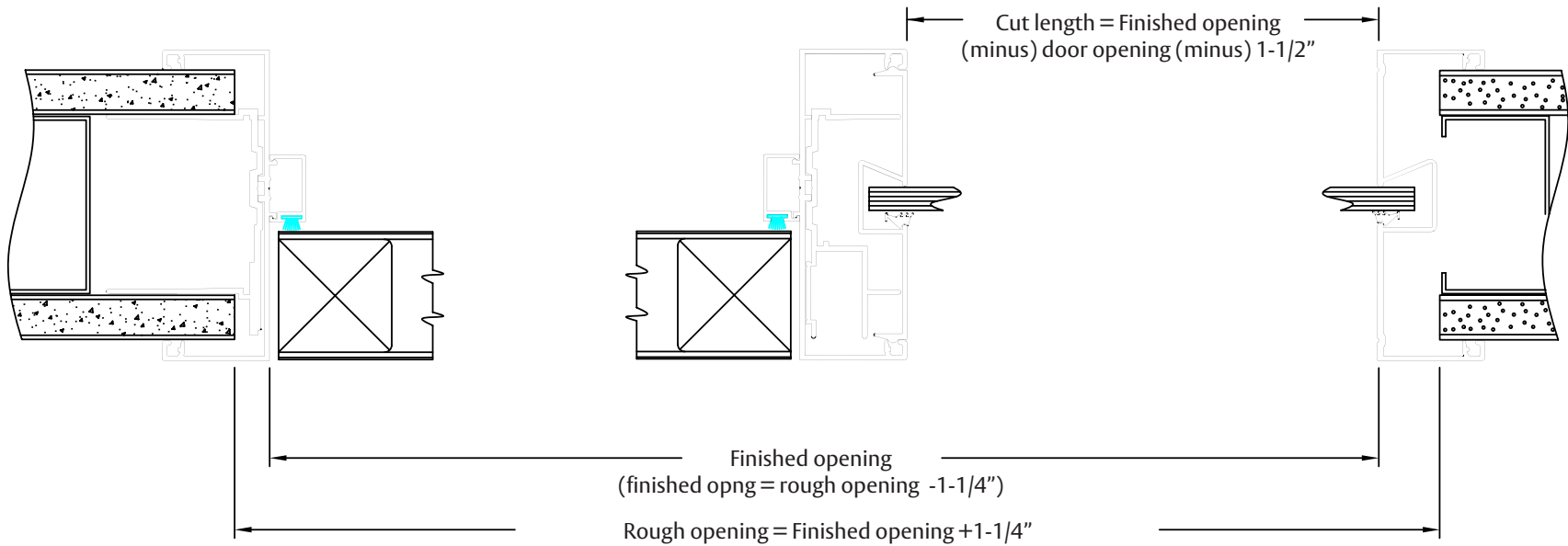

Type I Rough Opening Requirements

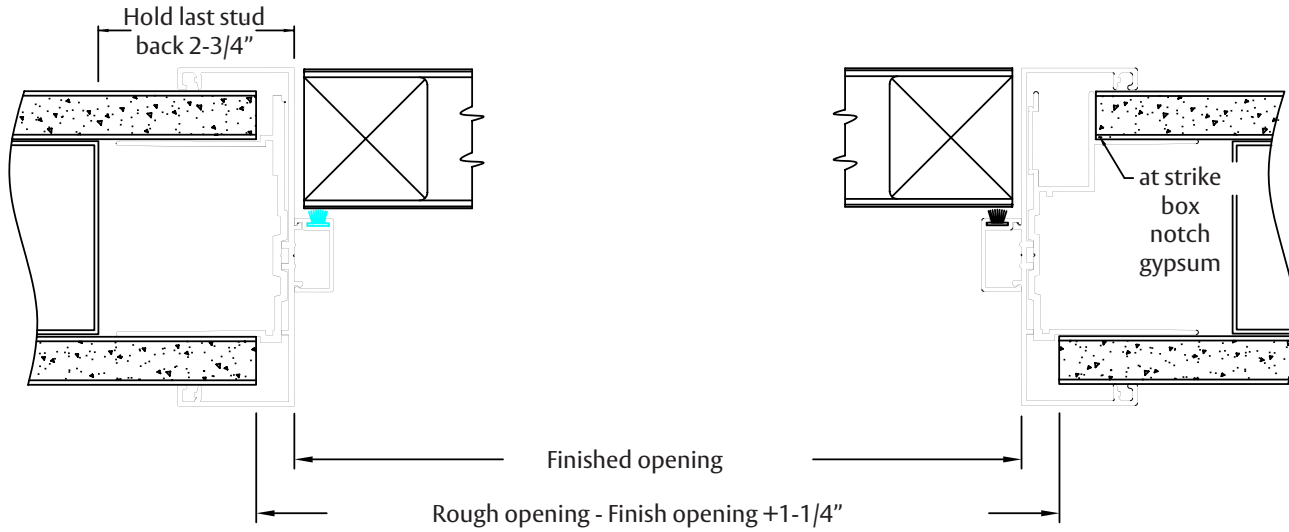
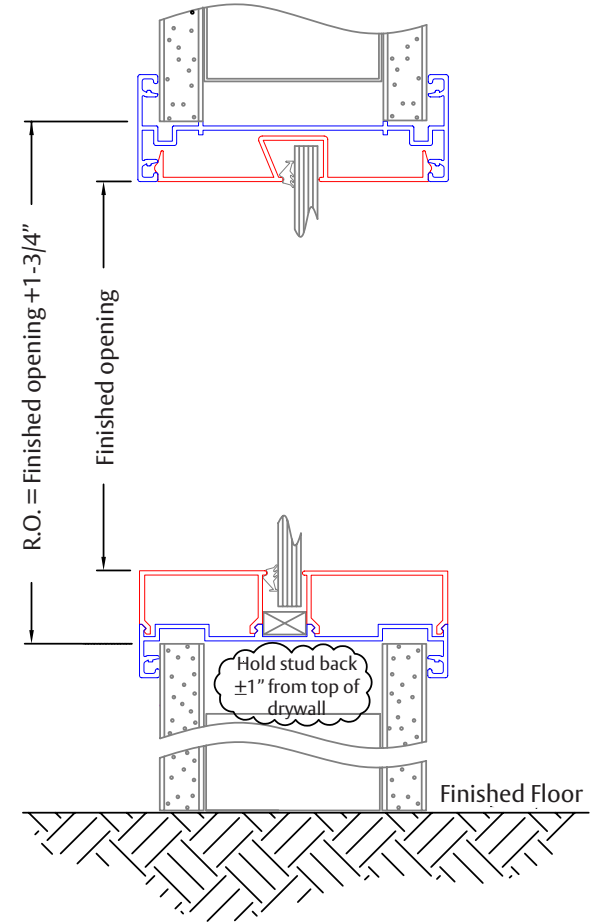
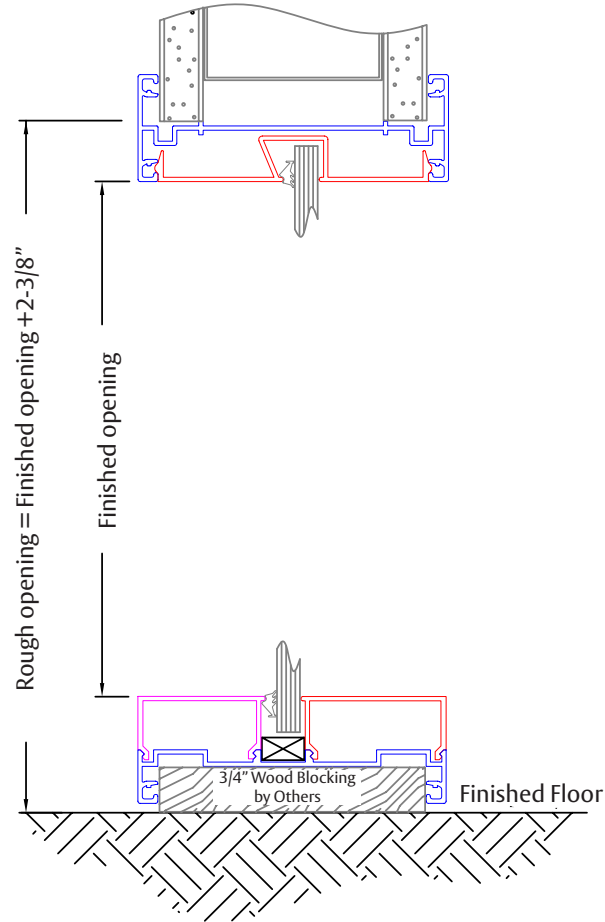
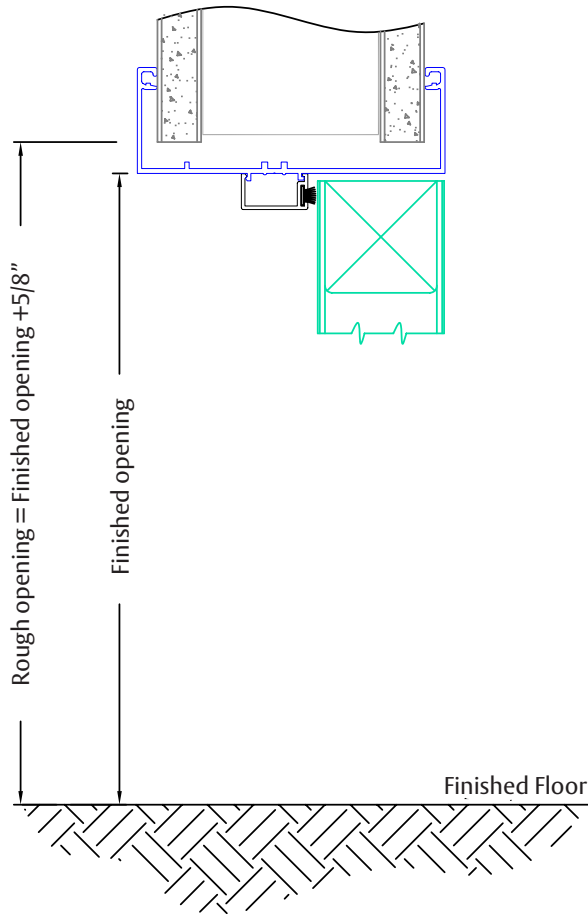

Type I Rough Opening Requirements

IMPORTANT:
Provide this information to the drywall framing subcontractor

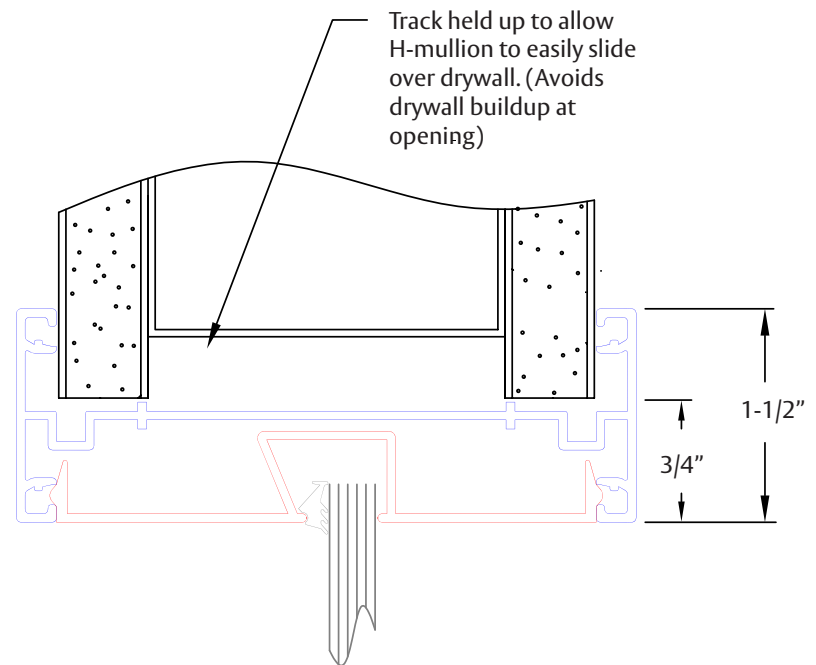
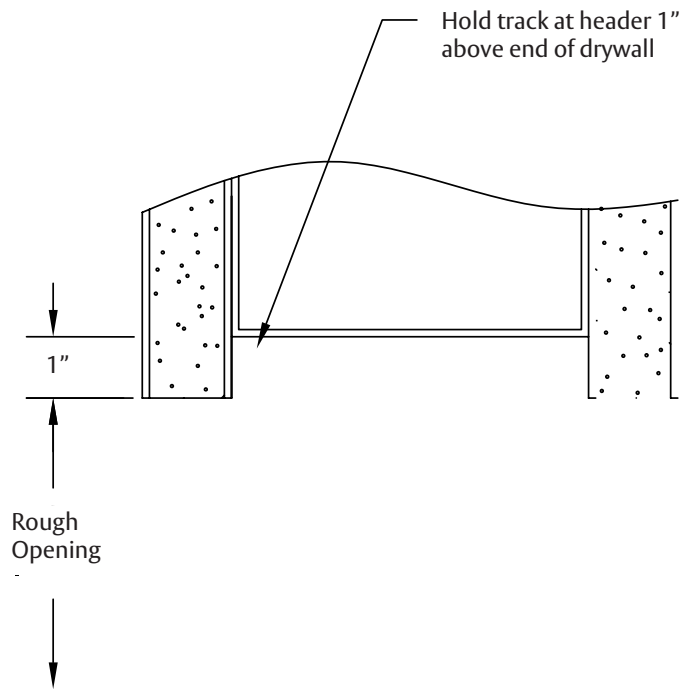

Steel Framing & Installation Requirements Aluminum Door Frames

Framing - Door Opening

“Door openings should be rough framed with steel studs and runners.

Position floor to ceiling height studs vertically, adjacent to frames and anchor securely to top and bottom runners with 5/8” type S-12 low profile head screws.

Install additional studs at jambs.

Fabricate sill and header sections from USG 20 gauge steel runners and install over less than ceiling height door frames.

Fabricate from a section of runner cut to length, approximately 6” longer than the rough opening.

Slit the web and bend up to allow attachment to adjacent vertical studs.

Securely attach through web to studs with 5/8” type S-12 low profile head screws.

Attach flange onto face of jamb stud with 2 each 5/8” type S-12 low profile head screws.”

UNITED STATES GYPSUM COMPANY GYPSUM CONSTRUCTION
HANDBOOK

