

Frameworks Manufacturing Barn Door Kit and Sizing Guide



Barn Door Installation Kit

Sliding Door Track
1x per opening
4100SDT12-6xx

Angle Mounting Channel
1x per openingz
1100CA12-0MIzzz

Rollers
2x per leaf
#1125-r



Track, rollers, stops & guides provided by Frameworks

Track Cover Trim
2x per opening
4100SDC12-6xx

Hangar Brackets
2 per leaf
#1125-h



Floor Guide
1x per leaf
BOACC-FLRGD

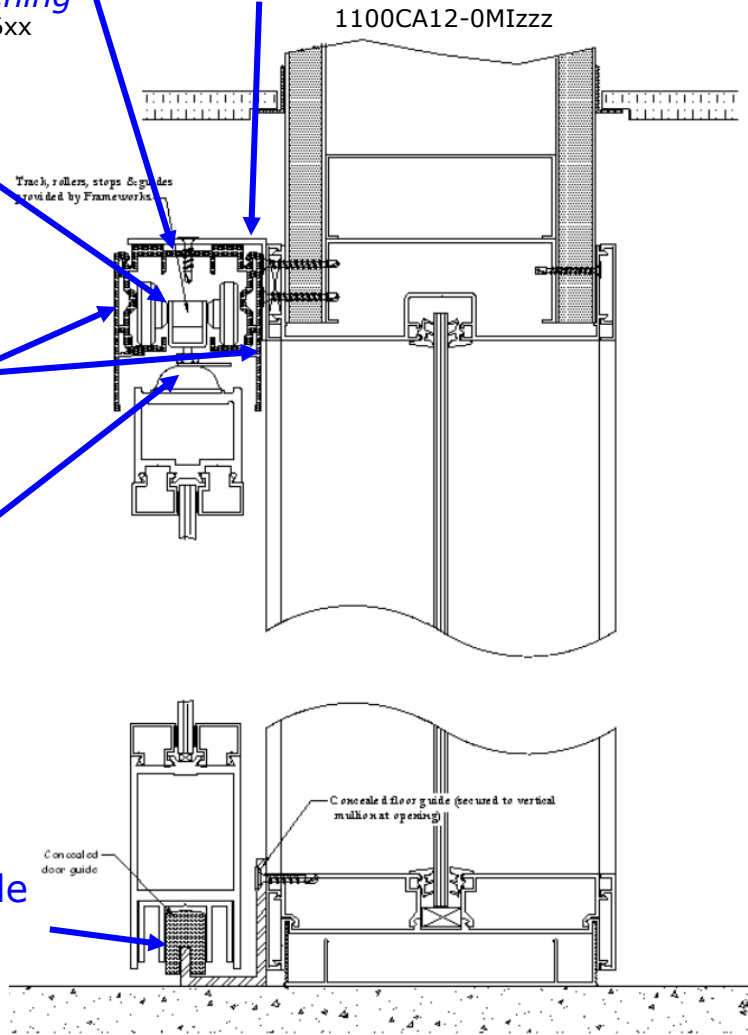

Components Not shown in drawing

Door Stops (x2 per leaf)



#1155

Friction Brakes (2x per leaf)



BOACC-FRCBRK

Track end covers (x2 per opening)



BOACC-TRKCVR

Mounting Screws (x20 per opening)



SDZ114



Type 1 frame shown. Kit is same for Type 2 or cased opening barn door applications

Installation Video

Barn Door Kit - Contents

<u>Part</u>	<u>Description</u>	<u>Qty</u>	<u>Packaged</u>
a 4100SDT12-6xx	Sliding Door Track	1 per opening	Wrapped in paper
4100SDC12-6xx	Track Cover	2 per opening	Wrapped in paper
1100CA12-0MI	Angle Mounting Channel	1 per opening	Wrapped in paper
b #1125-r	Tricycle Rollers	2 per leaf	Inside track
#1125-h	Hanger Brackets	2 per leaf	*Installed on Door for AL Doors †Installed on Rollers for Wood Doors
c #1155	Door Stops	2 per leaf	Inside track
BOACCK-FRCBRK	Track Brakes	2 per leaf	Inside track
d BOACCK-TRKCVR	Track End Caps	2 per opening	1 installed in track, 2 nd wrapped with hardware
e SDZ114	Mounting Screws	20 per opening	In plastic bag, taped to track
BOACCK-FLRGD	Concealed Door Guide	1 per leaf	*Shipped with the door for AL Doors †In a bag with screws for Wood Doors

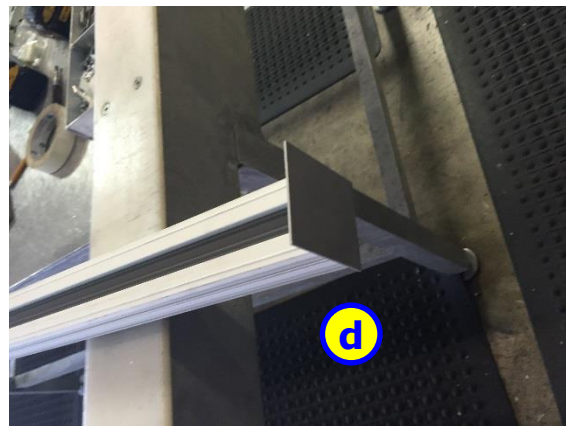
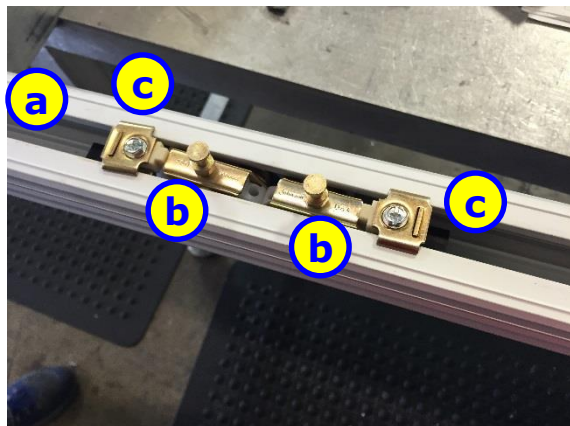

Bottom Prep procedure for Wood Doors

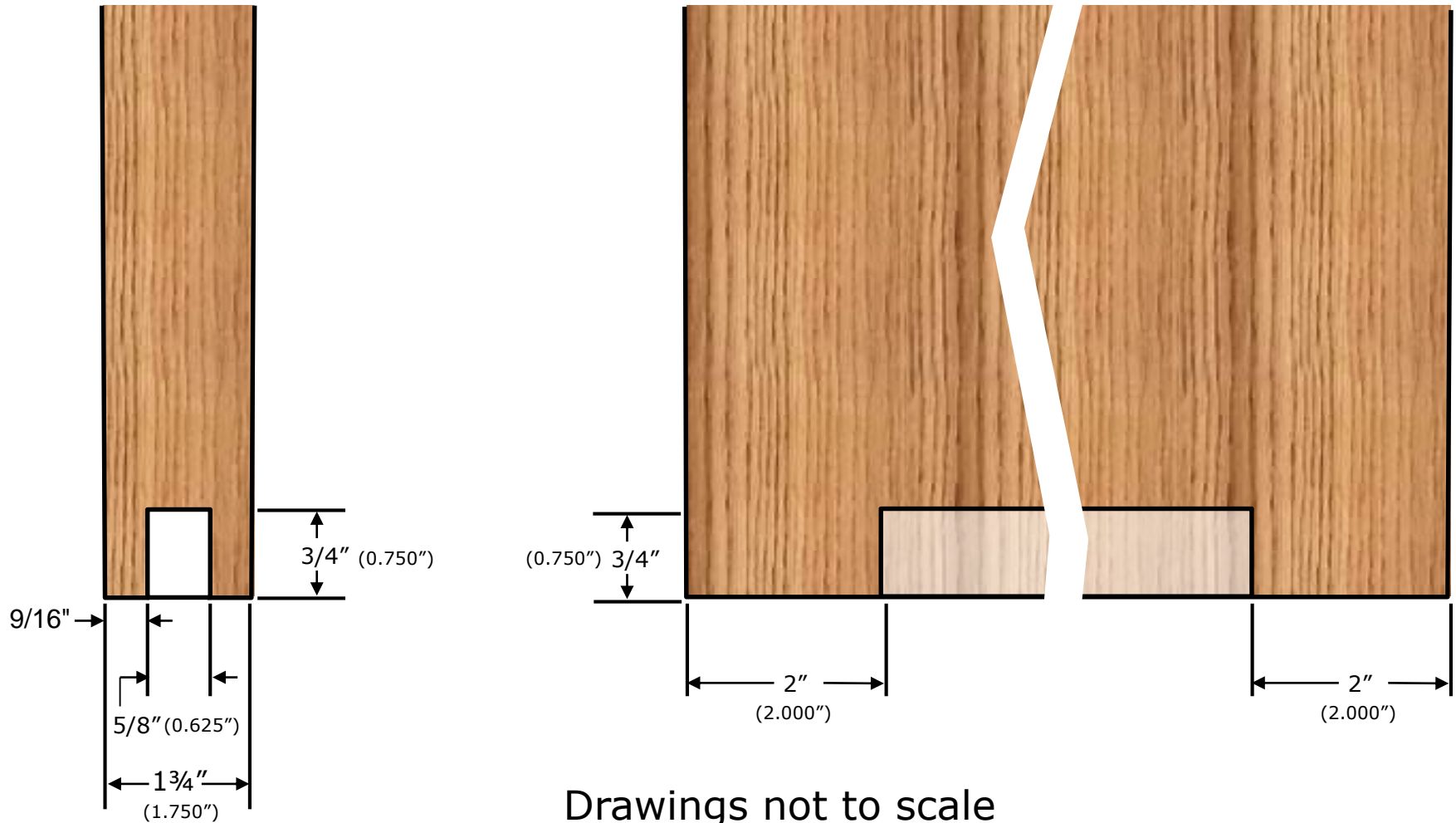

Measuring Final Door Size for Sliding Doors

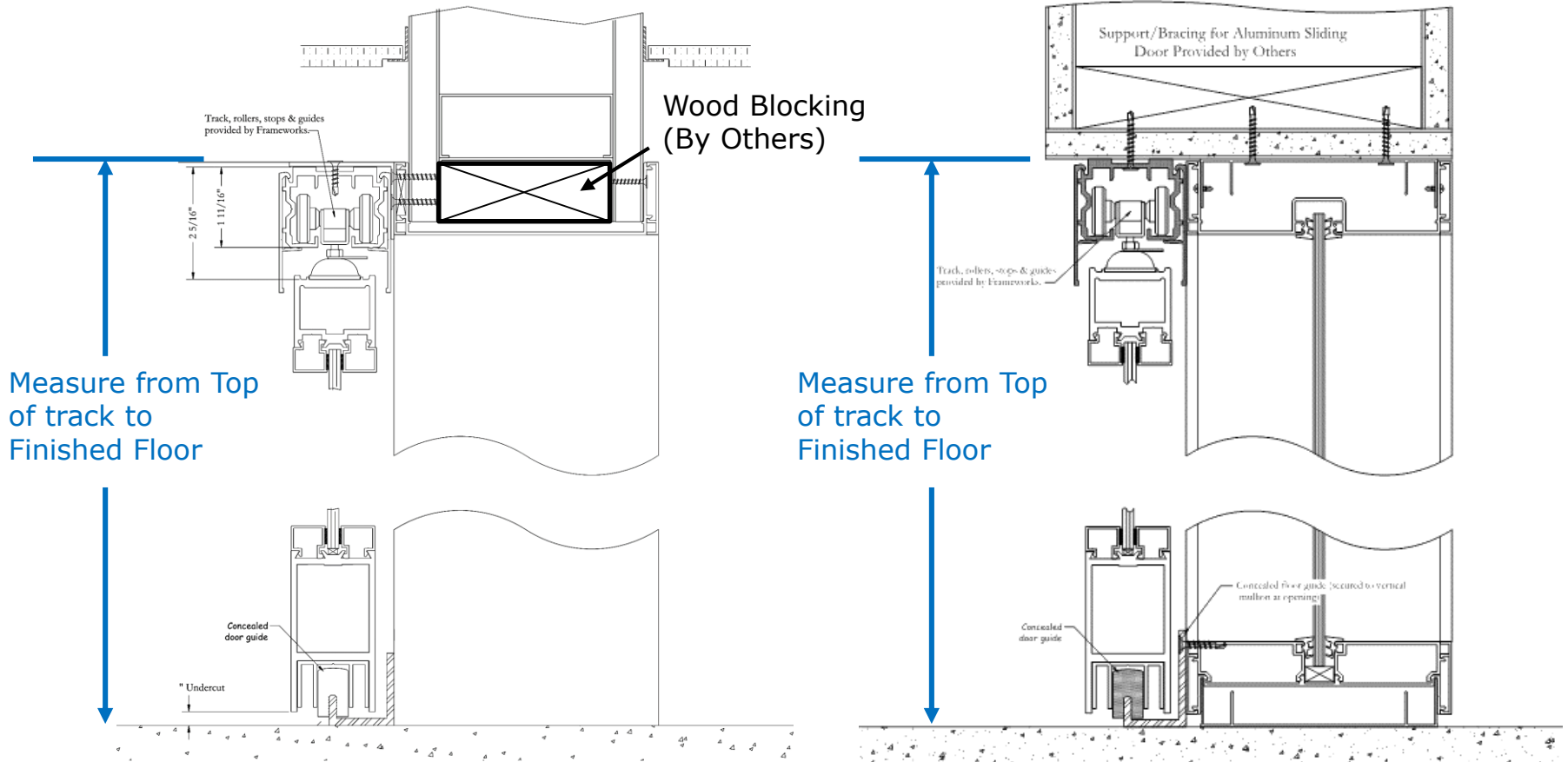

In order to ensure your barn-style or Slim Slider door fits the opening perfectly, you will need to measure the opening after frames are installed and provide those measurements to Frameworks.

Net Door Sizing – Barn Doors

- Dimension from the top of the sliding door track to the top of the door is 2-1/4"
- Additional undercut is required at the bottom rail to clear the floor
 - Use 3/4" for the undercut on barn sliding doors
 - Formula for **net door height** is top of track to floor less 3"
- For net width, door opening + the vertical frame jambs
 - If using 1-1/2" face frames, net width is door opening + 3";
 - if 2" face, door opening width + 4"
- There is vertical adjustment in the rollers of 1/4" up or down

Example calculation

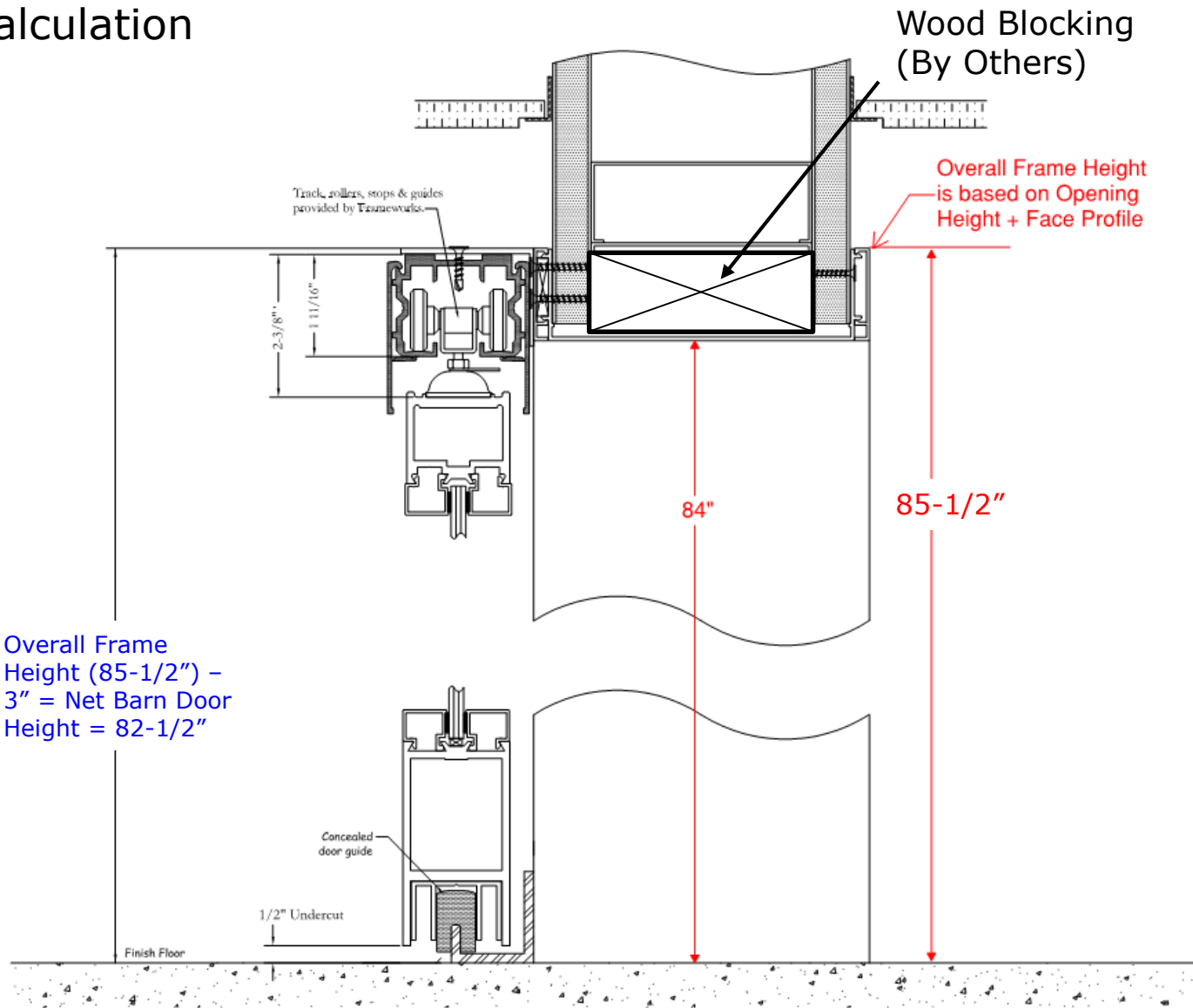

Barn Door – Sample Elevation – No Sidelite

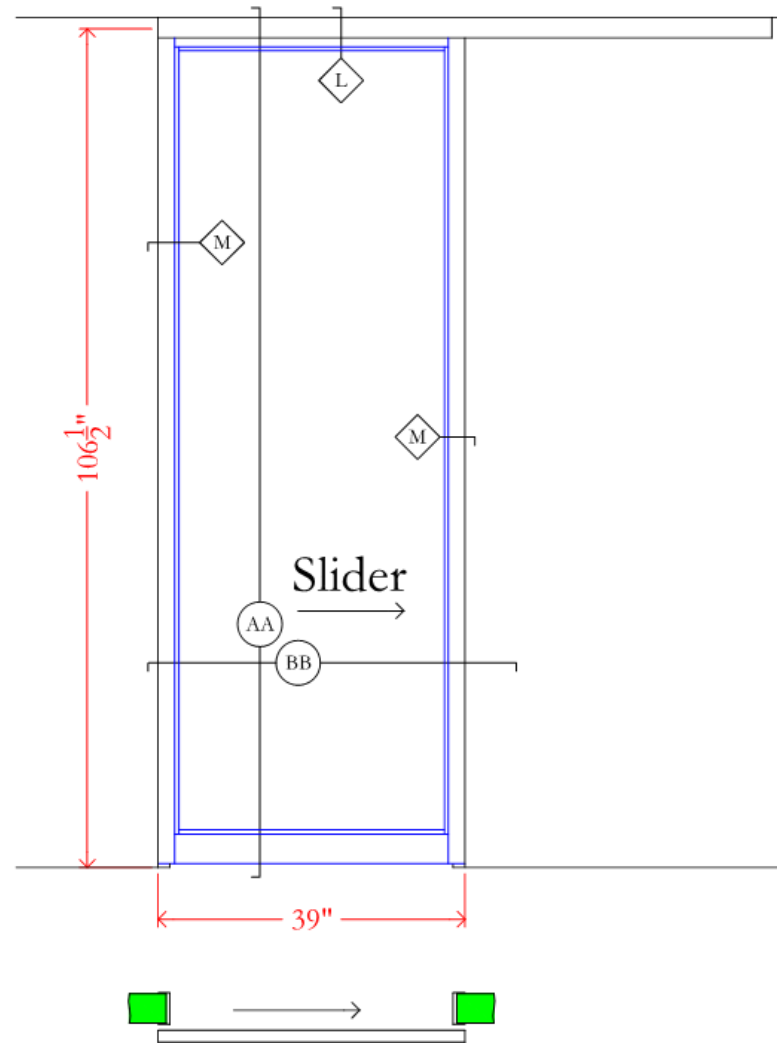

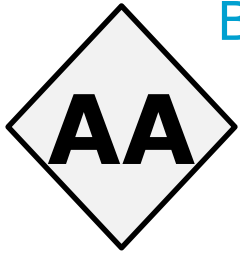

Barn Door – Sample Elevation – No Sidelite

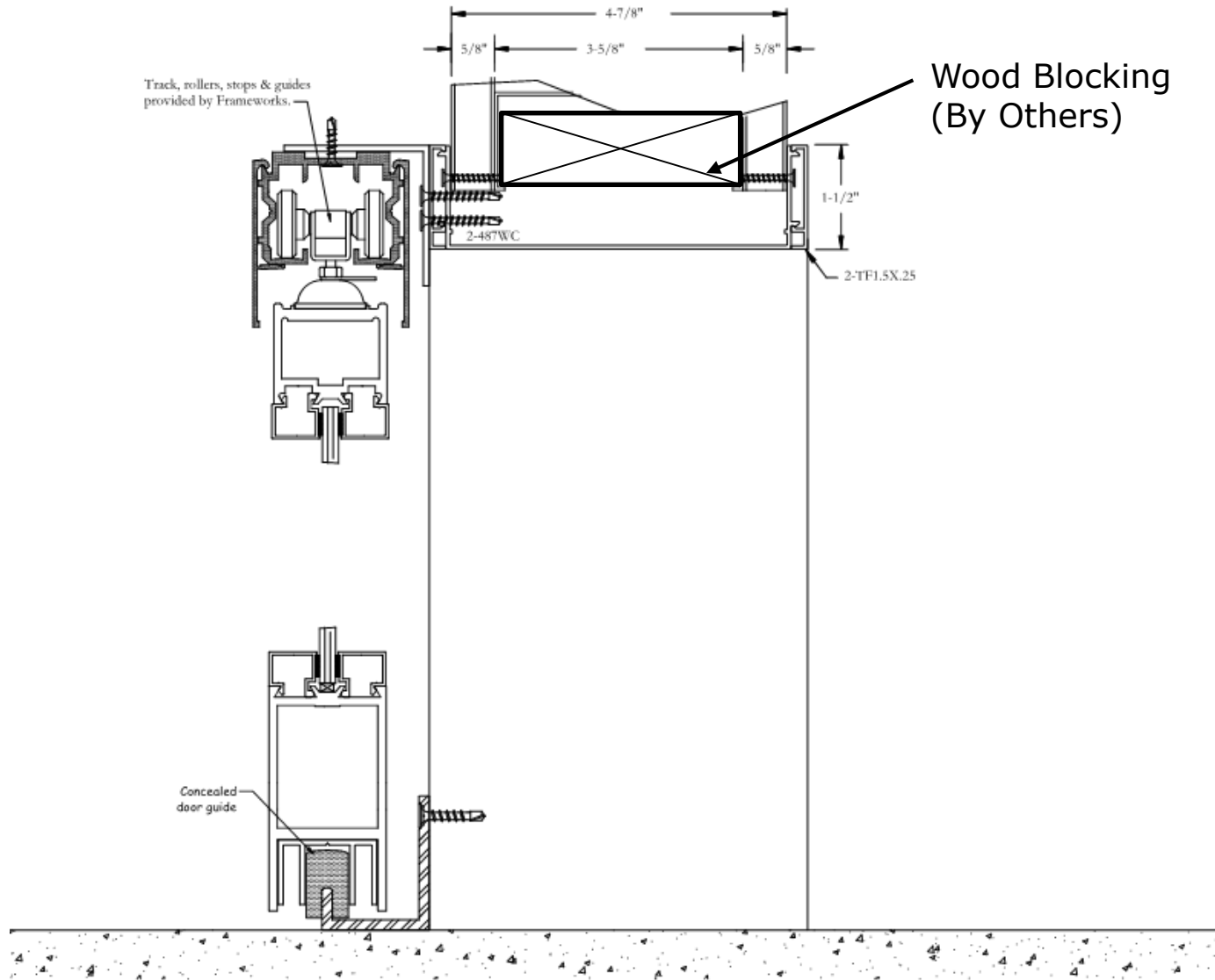

Barn Door – Sample Elevation – No Sidelite

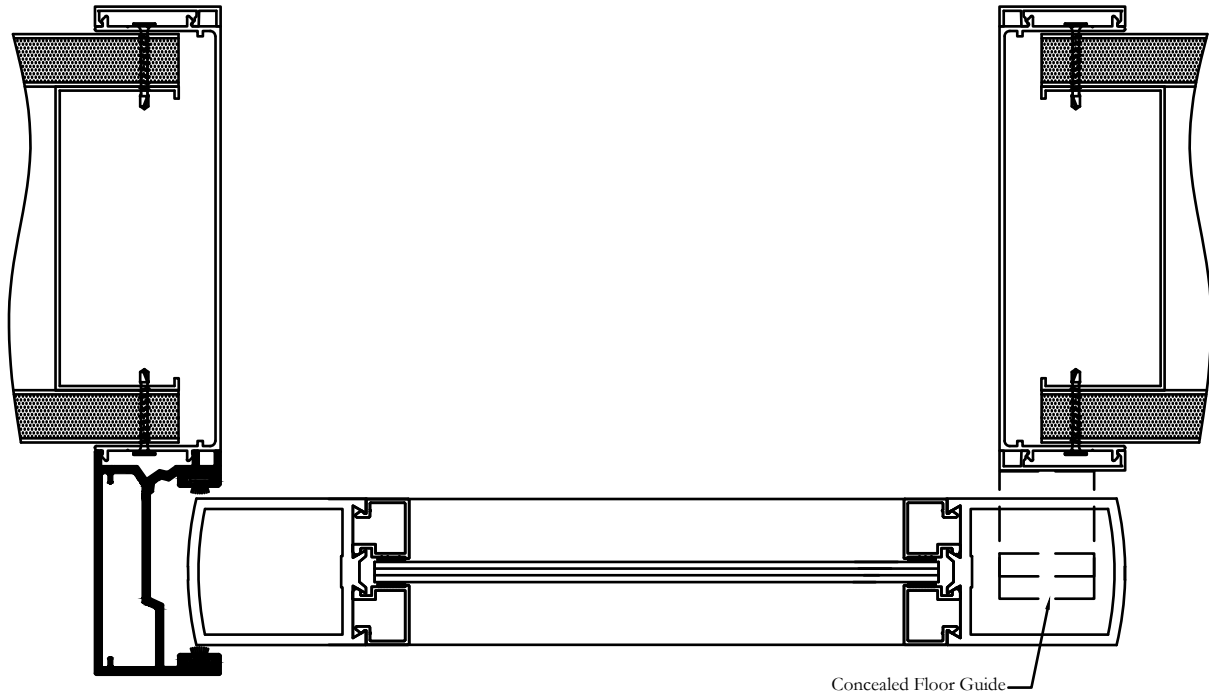
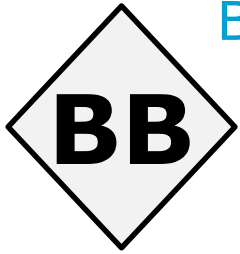

Barn Door – Sample Elevation – No Sidelite

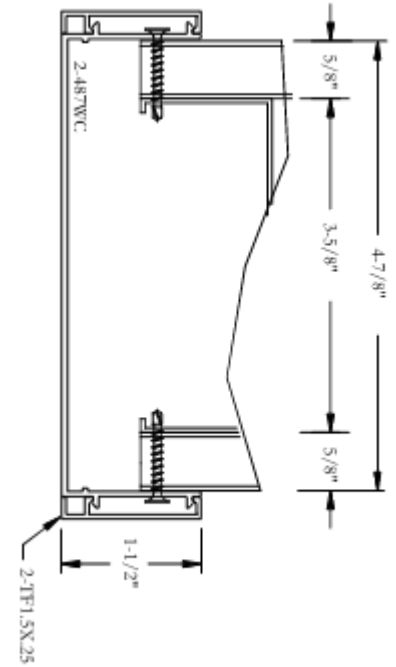
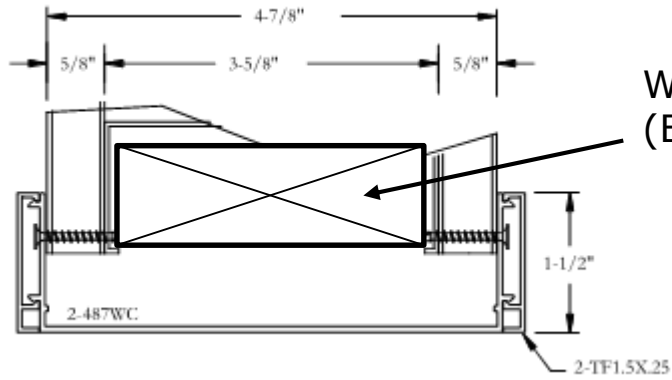
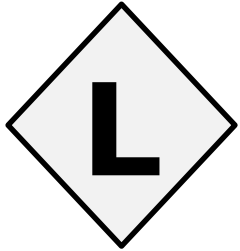

Barn Door – Sample Elevation - Sidelite

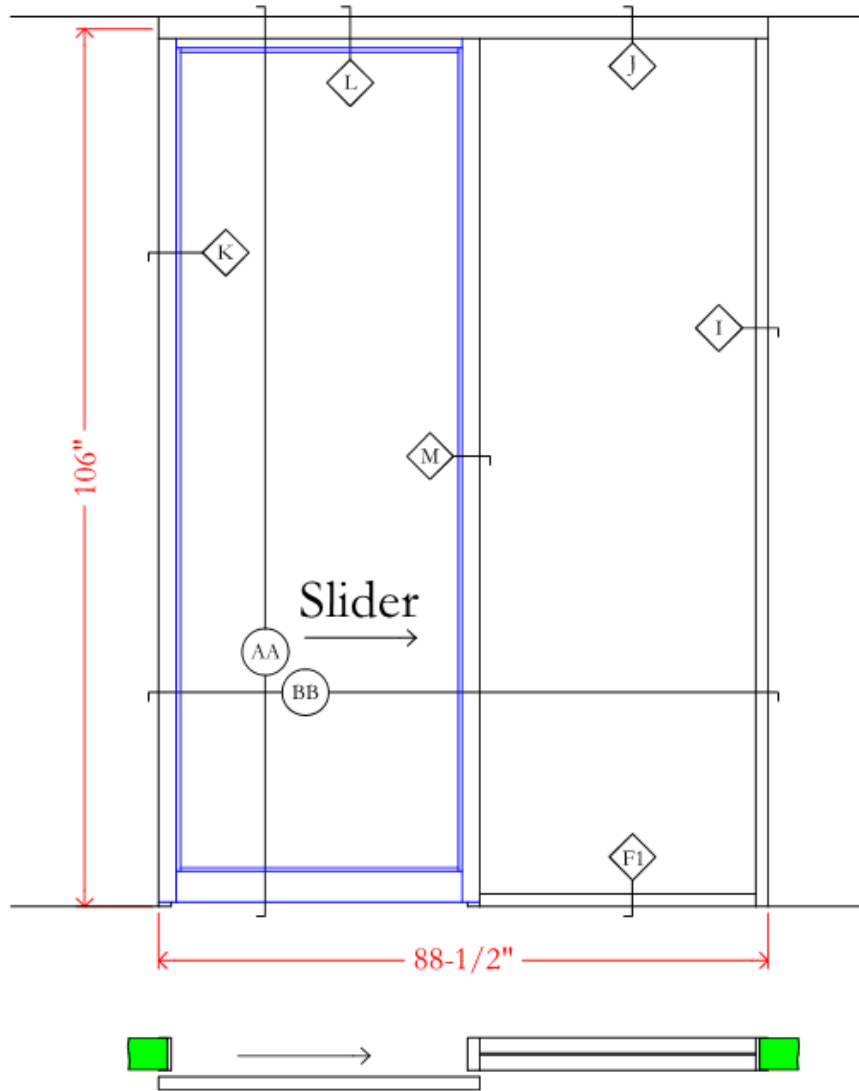

Barn Door – Sample Elevation - Sidelite

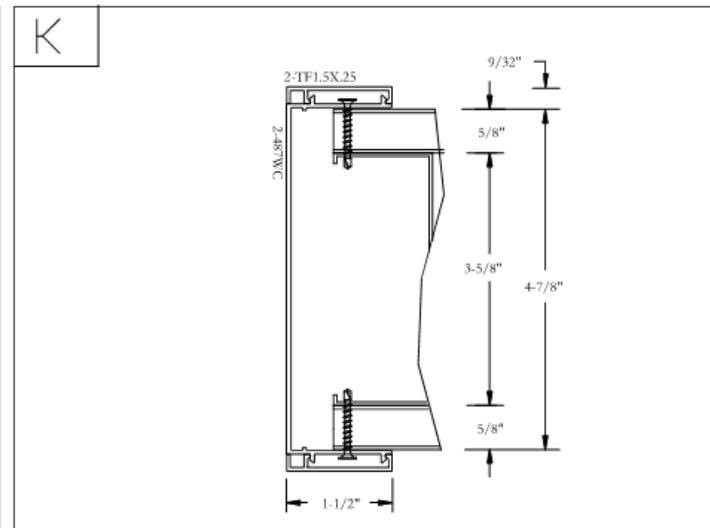
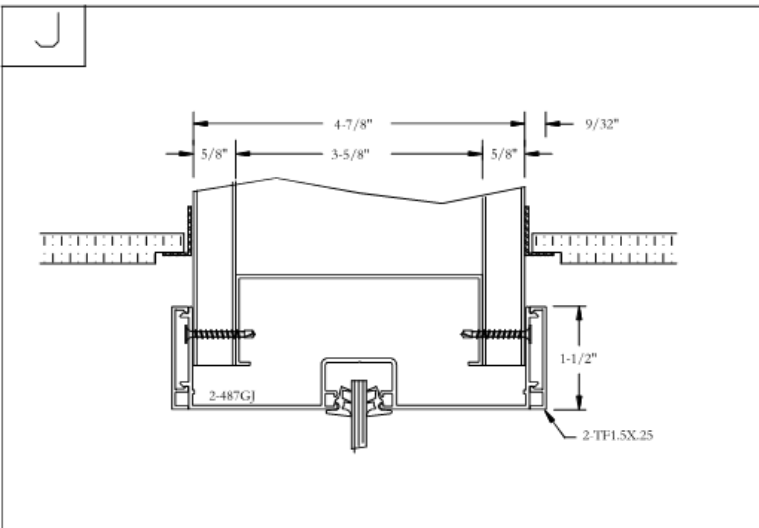
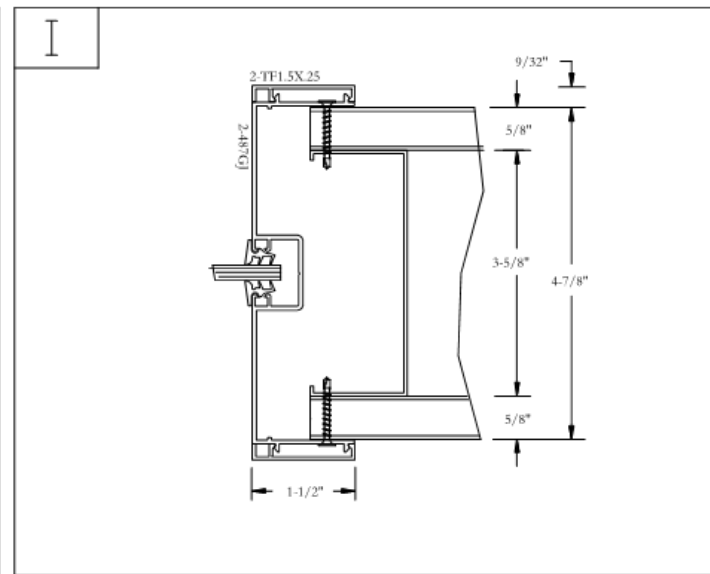
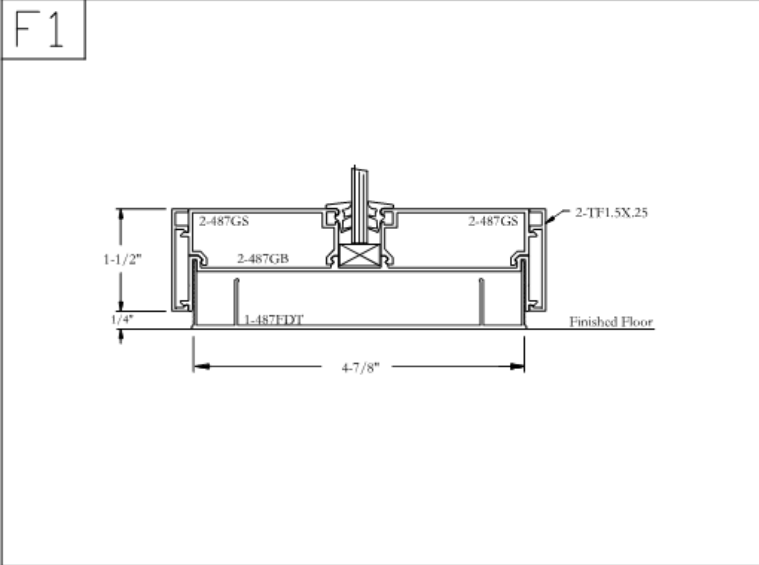

Barn Door – Sample Elevation - Sidelite

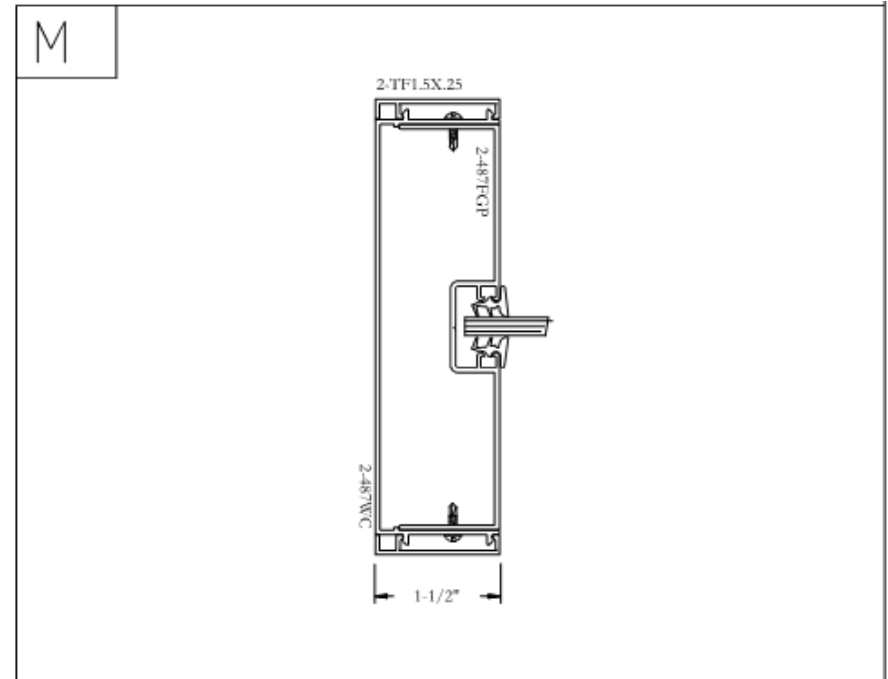
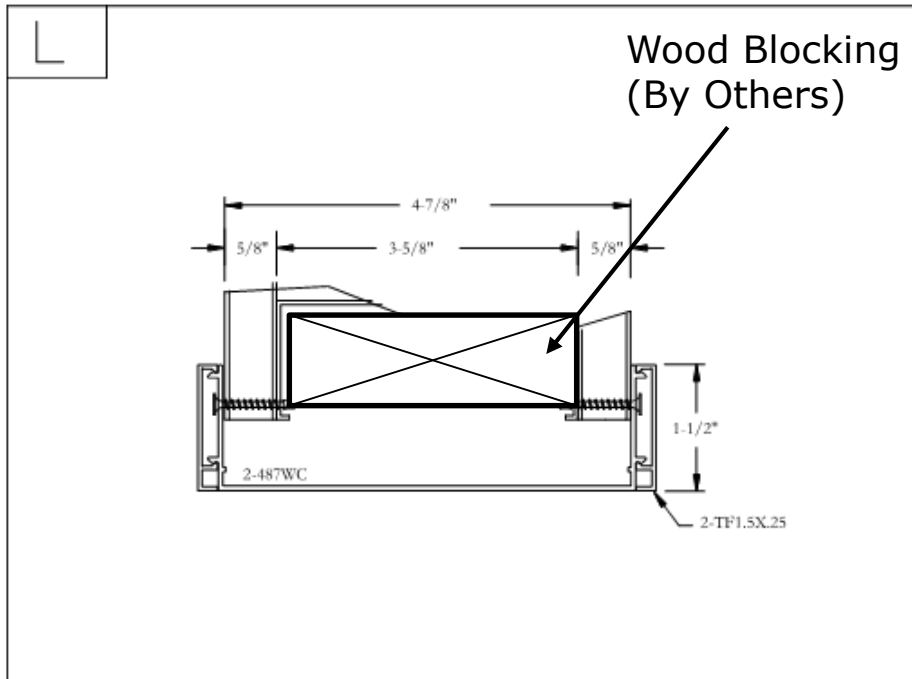

Barn Door – Sample Elevation - Sidelite

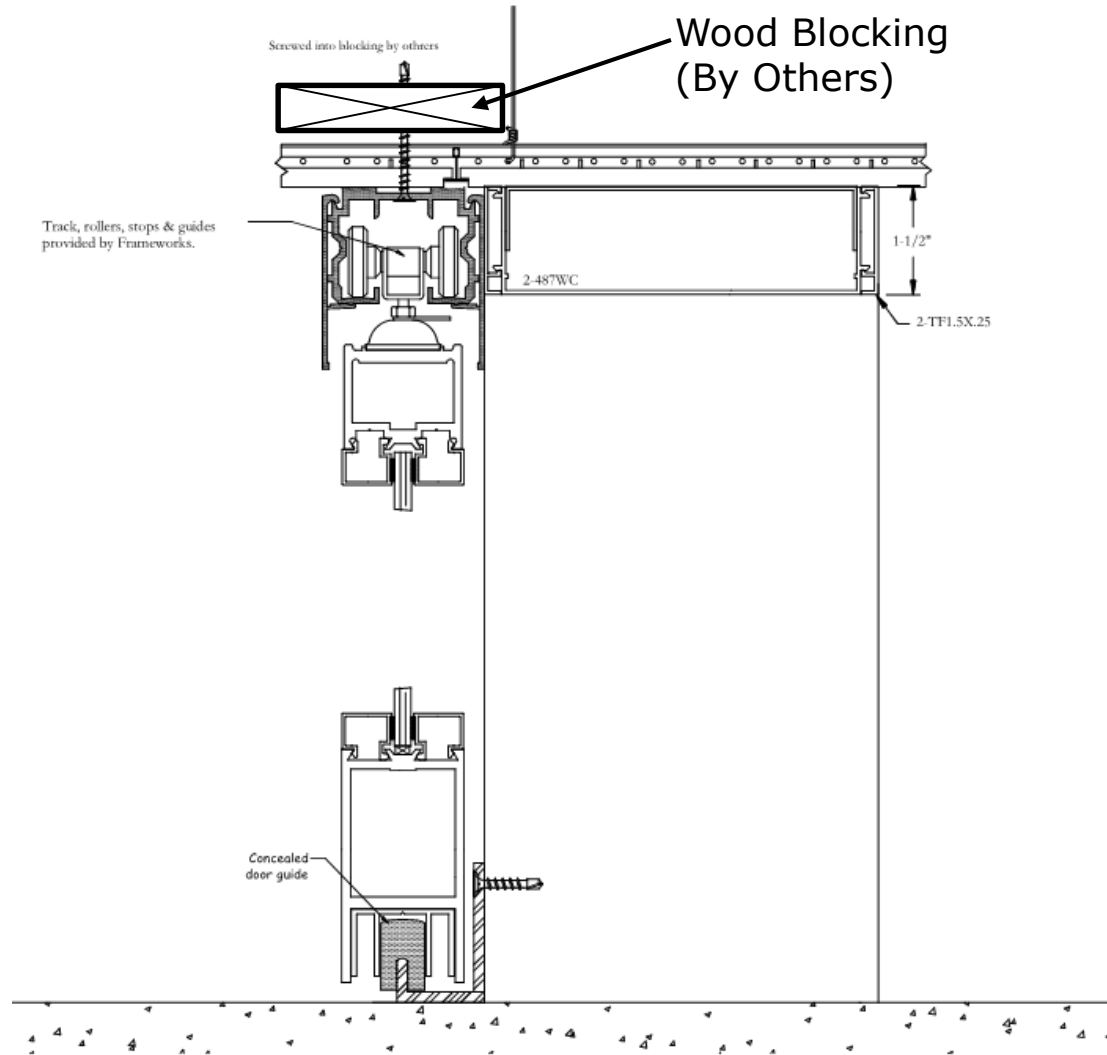
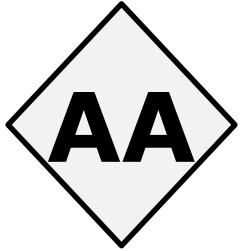

Barn Door – Sample Elevation - Sidelite

